

**BELL SYSTEM PRACTICES**  
**Station Installation and Maintenance**

**SECTION C32.539**  
**Issue 2, June, 1954**  
**AT&T Co Standard**

# **500 SERIES TELEPHONE SETS**

## **(500 AND 501 TYPE)**

### **MAINTENANCE**

#### **1. GENERAL**

1.01 This section covers requirements and procedures for the maintenance of the following sets:

#### **500 Type**

500A/B	500E/F	500J/K
500C/D	500H	500L/M

#### **501 Type**

501A/B	501F
501C/D	501J/K

1.02 This section is reissued to include data on the assembly of replaceable units and to bring the information up-to-date. Due to extensive changes, marginal arrows have been omitted.

1.03 The maintenance of handsets, dials, ringers, and other components of the 500 series telephone sets shall be in accordance with the sections dealing with these apparatus items.

1.04 Sections dealing with description, installation, connections, and cording of these sets should be consulted for information pertinent to the maintenance procedures covered in this section.

## 2. REQUIREMENTS AND PROCEDURES

### General

2.01 When the telephone set is dirty, clean the external surfaces and remove loose dust from the interior in accordance with instructions included in Section C30.012, Station Sets—Cleaning.

2.02 Make a careful visual inspection of the exterior and interior of the sets for obvious defects, such as loose, displaced or broken parts, obstruction of moving parts, or the presence of foreign matter that may interfere in some way with the proper operation of the set. Determine if any such defect was responsible for trouble condition before proceeding with corrective measures or more detailed maintenance procedures.

2.03 Check that all connections associated with screw terminals are secure at their respective terminals and that terminal screw threads are not stripped. Where stripped holes are found at the terminals of the network, the regular screws shall be replaced with P-174074 self-tapping screws, or approved equivalent.

### 3. ASSEMBLY OF REPLACEABLE UNITS

#### Housing Assembly

3.01 The housing is removed by loosening the two captive mounting screws located in the right front and left rear portions of the base.

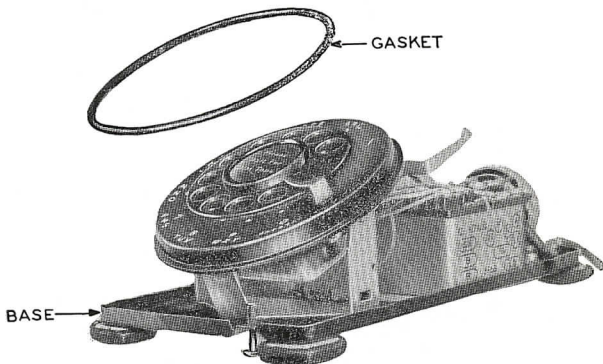
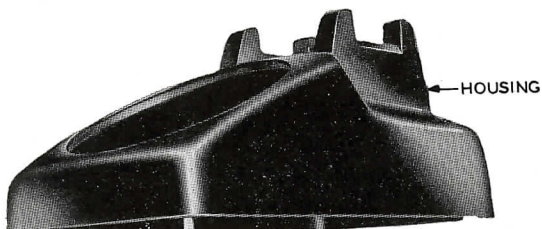
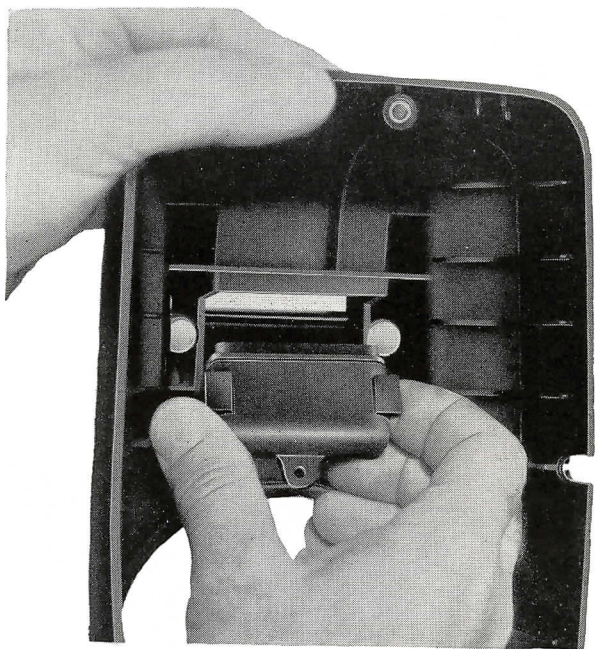

**Fig. 1—Housing Assembly**

3.02 When housing is replaced, gasket must be in place on outer rim of dial, cords properly anchored and in place, and housing aligned with base of set before tightening the two captive mounting screws.

### Plunger Assembly

- 3.03 Plungers are accessible by removing hand-hold cover mounting screw and the hand-hold cover.



**Fig. 2—Plunger Assembly**

- 3.04 When reassembling, place lip of hand-hold cover beneath lip of housing and slide cover into place. Center cover so plungers will not fall past and replace screw.

## Dial Assembly

3.05 To remove dial assembly, disconnect dial leads at their respective terminals on the network, loosen mounting screws and slide unit from bracket.

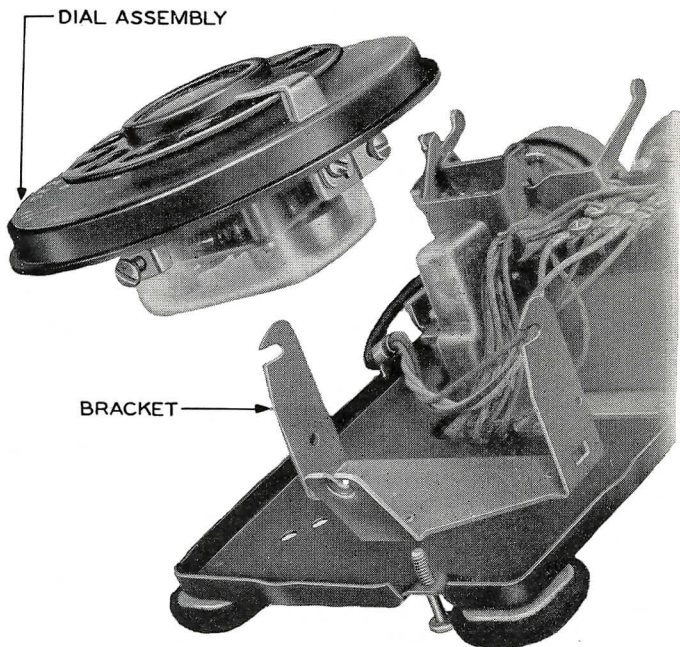

Fig. 3—Dial Assembly

3.06 To install: (1) Slide dial assembly into position and tighten mounting screws. (2) Connect dial leads to their proper terminals and dress dial leads to avoid interference with movement of the operating bracket of the switch assembly.

### Tube Assembly—(501-Type Sets)

3.07 The 426A tube assembly is removed by disconnecting the yellow, black, and red tube leads from their respective terminals on the network and removing the tube assembly mounting screw.

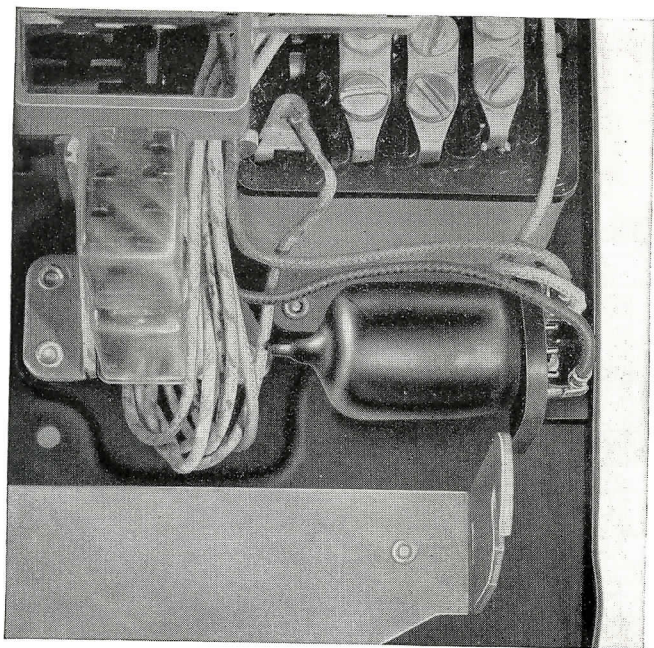

Fig. 4—Tube Assembly

3.08 Install tube assembly as follows: (1) Slide tube assembly into position and replace mounting screw. (2) Connect tube leads to their proper terminals and dress leads to avoid interference with movement of operating bracket.

## Ringer Assembly

3.09 C3A ringer is removed by disconnecting the black and red ringer leads from their respective terminals on the network and removing the two ringer assembly mounting screws and lock washers.

3.10 C2A or C4A ringers are removed by disconnecting the black, red, slate, and slate-red ringer leads from their respective terminals on the network and removing the two ringer assembly mounting screws and lockwashers.

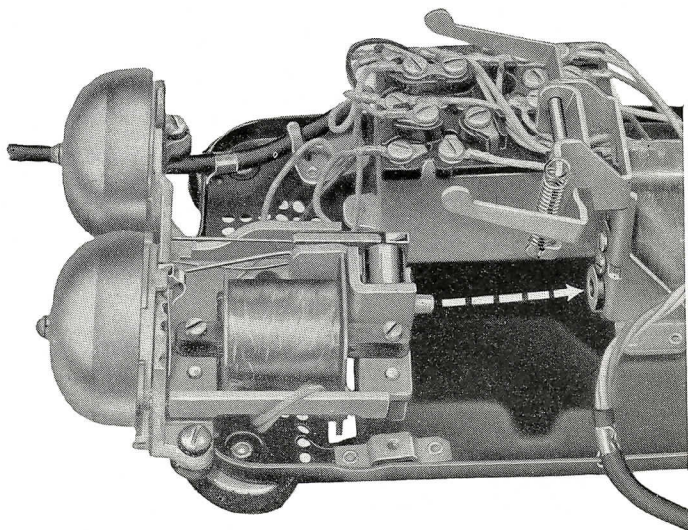

Fig. 5—Ringer Assembly

3.11 **Install ringer assembly as follows:**

- (a) Place ringer leads beneath coil and dress from left to right.
- (b) Slide ringer assembly into position by locating guide pin in grommet hole of switch assembly mounting.

- (c) Align ringer assembly so that volume control knob is parallel with the slot in the base. The control knob should turn freely without binding.
- (d) Replace the two ringer assembly mounting screws and lockwashers.
- (e) Connect ringer leads to their proper terminals, and dress ringer leads between frame of network and right-hand ringer gong mounting to avoid interference with gong.

### Cord Assembly

3.12 To disconnect either the handset or mounting cord from the set base, disconnect cord leads from their respective terminals on the network and hold ferrule of stay hook at right angles to base and remove stay hook from base slot.

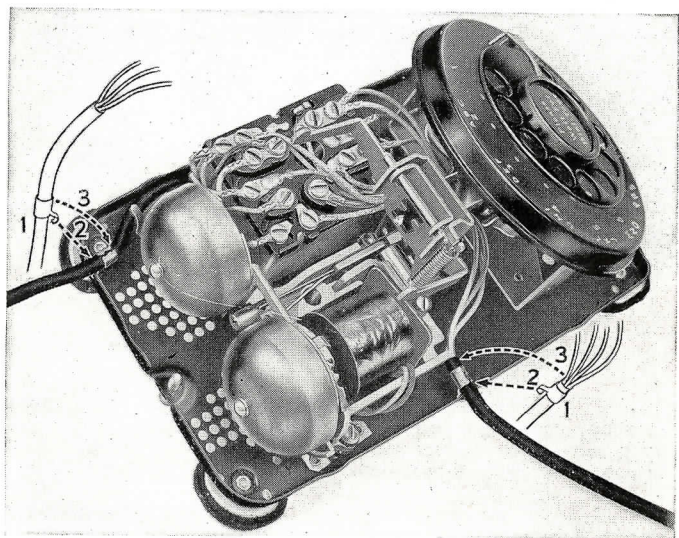

Fig. 6—Cord Assembly



3.13 To connect either cord to the set base, (1) Hold ferrule of stay hook at right angle to base. (2) Slide stay hook into base slot. (3) Tilt ferrule of stay hook parallel to base which locks stay hook in slot. (4) Connect cord leads to their respective terminals on the network and dress to avoid interference with moving parts and ringer gongs.

**Note:** Anchor mounting cord beneath stay hook in right rear corner of base to prevent interference with ringer gong.

### Handset Assembly, G1-Type

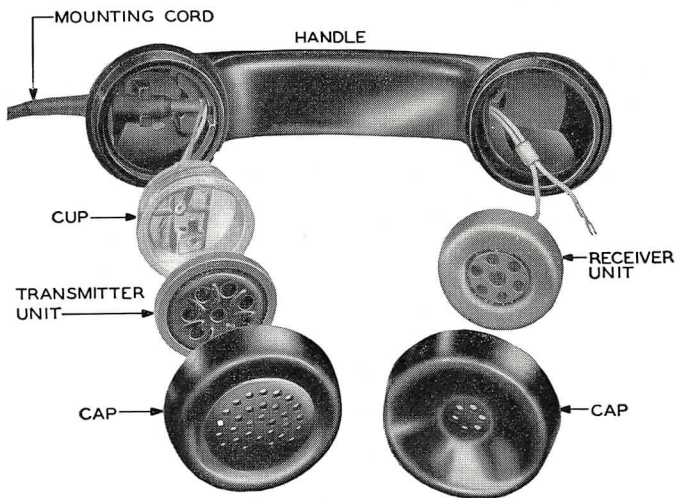
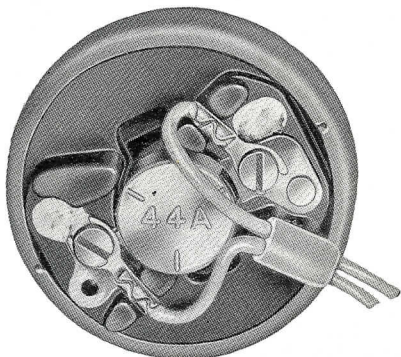

Fig. 7—Handset Assembly, G1-Type



**Fig. 8—Transmitter Cup, G1-Type Handset**

3.14 When the handset cord leads are connected to transmitter cup terminals, the spade tips are pushed forward toward the raised shoulder molded on the cup before tightening terminal screws.



**Fig. 9—Receiver Unit, G1-Type Handset**

3.15 When the handset cord leads are connected to receiver unit terminals, the shank of the spade tips are placed between the guides molded on the receiver unit before tightening terminal screws.

#### 4. MAINTENANCE

4.01 Table A lists a number of troubles that may occur in these sets, the probable causes, and corrective measures to be taken. It assumes that an OK test has been made of the line (and ground) termination at the connecting block, jack, or equipment terminals.

**TABLE A**

<b>Trouble</b>	<b>Probable Causes</b>	<b>Corrective Measure</b>
1. Bell does not ring	Ringer disconnected or wired wrong in set	Connect correctly.
	Volume control wheel in cut-off position	Move control wheel to ring position.
	Open winding	Replace ringer.
	Metal particles in armature gap	Remove particles with scotch tape or approved equivalent.
	No ground (party lines)	Check ground circuit.
	Open tube	Short-circuit yellow and black tube leads and, if ringer operates when ringing voltage of correct polarity is applied, replace tube.

TABLE A (Cont.)

Trouble	Probable Causes	Corrective Measure
2. Bell too loud	Volume control wheel in wrong position	Move control wheel to most favorable position and advise customer how to use it.
	Gong loose	Tighten screw as required.
3. Bell not loud enough	Volume control wheel in wrong position	Move control wheel to louder position and advise customer how to use it.
	Set on sound-absorbent material	Place set on hard surface.
	Cord touching gong	Dress cord properly.
4. Bell taps while dialing or operating switch	Incorrect wiring	Check line cord and ringer connections.
	Biasing tension too low	Place biasing spring in high-tension notch. If ringer still taps, replace ringer.
5. Bell rings when other party is called, cross ring or false ring	Incorrect wiring	Check line cord and ringer connections.
	Biasing tension too low	Place biasing spring in high-tension notch. If ringer still cross rings, replace ringer.

6. Bell keeps ringing when handset is removed	Open in handset cord, or at dial pulse contacts	Replace handset cord or dial.
	Open induction coil, equalizer filament or set wiring	Replace telephone set.
	Line contacts on switch do not close	Check switch cover, ears should fit into notches.
7. Bell rings. No one on line	Open handset cord or receiver unit	Replace handset cord or receiver unit.
	Dial "off normal shunt" contacts closed	Replace dial.
	Open induction coil or transmission condenser	Replace telephone set.
	Switch receiver contacts do not open	Check switch cover.
8. No dial tone or set dead	Open mounting or handset cords	Replace cord.
	Defective receiver unit or varistor shorted	Replace receiver unit.
	Dial pulse contacts open or "off normal shunt" contacts closed	Replace dial.
	Open induction coil	Replace telephone set.
	Switch contacts do not operate	Check switch cover.

TABLE A (Cont.)

Trouble	Probable Causes	Corrective Measure
9. Cannot break dial tone	Dial pulse contacts do not open	Replace dial.
	Dial filter condenser shorted	Replace telephone set.
10. Loud clicks while dialing	Dial "off normal shunt" contacts do not close	Replace dial.
11. Cannot hear	Open or shorted receiver unit or handset cord	Replace receiver unit or handset cord.
	Dial "off normal shunt" contacts closed	Replace dial.
	Open in induction coil or in network	Replace telephone set.
	Switch receiver contacts do not open	Check switch cover.
12. Distant party cannot hear	Defective transmitter or handset cord open	Replace transmitter or handset cord.
13. High sidetone	Defective sidetone balancing network	Replace telephone set.
14. Interference from radio station	Proximity to radio station	Refer to Section C32.537.
15. Induced low frequency noise	Unbalanced power and ground condition	Refer to Section C63.271.

16. Dial lamp does not burn	Lamp burned out	Replace lamp.
	Transformer plug out of receptacle	Replace plug.
	Transformer winding open	Replace transformer.
	No power at AC receptacle	Check with subscriber (possible blown fuse or power controlled by switch).

### Plungers

4.02 Both plungers shall move freely without binding or squeaking throughout their entire travel. Where binding or squeaking exists, remove housing and determine cause. Clean plungers and plunger holes with a KS-2423 cloth moistened with KS-7860 petroleum spirits. If binding or squeaking continues after cleaning, replace the plungers.

### Operating Bracket—Switch Assembly

4.03 The operating bracket shall function without binding or squeaking when removing or restoring the handset. If necessary, remove housing and determine cause. Clean the following bearing surfaces with a KS-2423 cloth moistened with KS-7860 petroleum spirits, bosses on operating bracket arms, spring anchor points, operating bracket, and shaft bearing points. Lubricate the previously cleaned bearing surfaces with No. 2 or softer graphite pencil. If after cleaning and lubrication, binding and squeaking continues, replace the set.

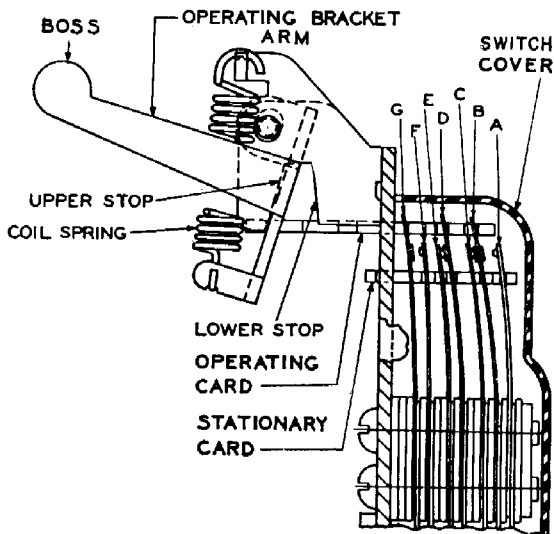

Fig. 10—Switch Assembly

### Switch Cover—Switch Contact Springs

4.04 To remove switch cover: (1) Depress sides of cover between thumb and second finger of left-hand to release ears on sides of cover from indents in the switch assembly mounting. (2) Tilt bottom of cover up and away from mounting. (3) Press down on top of cover with index finger to release ear on top of cover from its indent. (4) Remove cover. When installing cover: (1) Place ear at top of cover in its indent. (2) Depress sides of cover and push cover forward and upward until ears on sides of cover are in their indent. (3) Check that all cover ears are securely fastened in the indents in the switch assembly mounting.



**Note:** If cover ears are broken or not properly secured in their indents, change cover.

#### **Contact Cleaning—Switch Contact Springs**

4.05 Remove housing, dial assembly, and switch cover when necessary to clean crossbar contacts with a 265B tool.

**Note:** No field maintenance shall be performed on the switch contact spring assembly except replacement of the switch cover and cleaning of contacts. Replace set when required.

#### **Plunger Switch Assembly—(500E/F and 501F Type Sets)**

4.06 If left-hand plunger fails to lock when pulled upward to its extreme position, replace set.

4.07 If required burnish crossbar contacts with a 265B tool.

**Note:** No field maintenance shall be performed on the plunger switch assembly except cleaning of contacts. Replace set when required.

#### **Dial Light Assembly—(500H-Type Set)**

4.08 To replace lamp bulb: (1) Remove lamp cover by turning counterclockwise and lifting. (2) Unscrew lamp bulb by turning counterclockwise with tips of fingers. (3) Screw new lamp bulb firmly in place. (4) Replace lamp cover, turning it clockwise in its bayonet receptacle as far as it will go.

## Feet

4.09 Feet, or friction pads if present shall not be cut, worn, or have foreign matter imbedded in them to an extent which might scratch the surfaces on which the set is placed. If necessary the feet may be cleaned by rubbing briskly with a piece of cloth or a stiff bristle brush.

4.10 Feet that do not meet the requirements in 4.09 shall be equipped with triangular friction pad KS-8035. If the set is already equipped with friction pads and they do not meet specified requirements, they shall be replaced with new friction pads. The pads shall be applied as shown in Fig. 11.

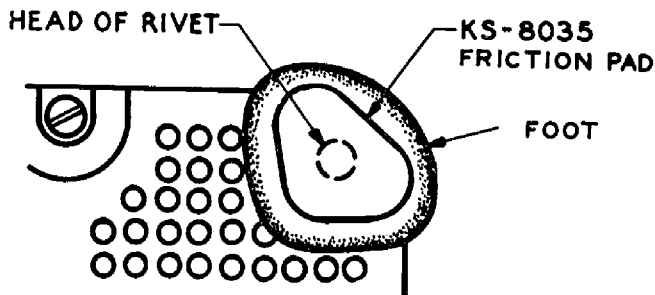

Fig. 11—Base Plate with Foot and Friction Pad Assembled

4.11 If any foot is missing, replace the set.

## 5. STATION TESTING

5.01 When the trouble condition has been rectified, make a test of the station in accordance with local practices, or as outlined in Section C61.711, Tests with Test Desk—Common Battery Stations.